

36 32 501 Renewing front tyre (wheel removed)

Equipment trim-level variant:

0530 - Tyre pressure control (RDC)^{OE}

Core activity

(-) Changing front tyre

► Removing front tyre

ATTENTION

Use of hard or sharp-edged objects in proximity to component

Component damage

- Take care not to scratch components; cover or mask as necessary.

- Pry tyre (1) off opposite (arrow) the valve/tyre pressure monitoring (RDC) sensor.
- Apply the lever to the rim at RDC sticker (2), to prevent the tyre bead from damaging the RDC sensor.
- Remove tyre (1) with commercially available tools.



► Checking battery for front RDC sensor

Check

- Check the battery for RDC sensor (1) with RDC test tool (No. 61 1 673).

Result:

- Battery is too weak.

Measure:

=> 36 20 554, Replacing front RDC sensor (tyre removed) (Billed as a separate item)



► Installing front tyre

- Hold the tyre in position, noting the RDC sensor.

ATTENTION

Use of hard or sharp-edged objects in proximity to component

Component damage

- Take care not to scratch components; cover or mask as necessary.

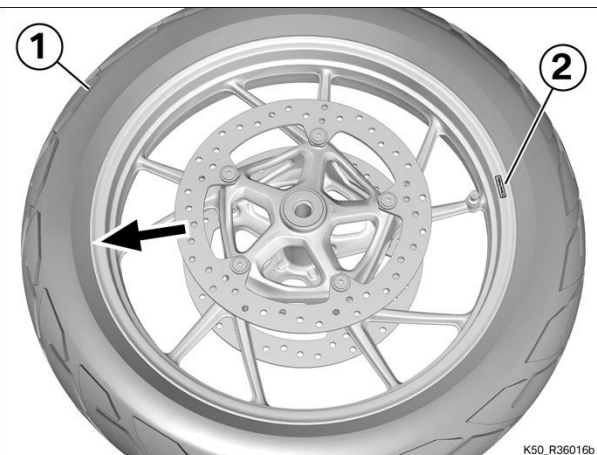

K50_R36016b



K52_R36018b

- Install the tyre in accordance with the manufacturer's instructions, using commercially available tools. Make sure that the direction-of-rotation arrows on tyre and rim point in the same direction.
- Manufacturer-specific tyre mark for imbalance must be toward the valve.
- Inflate the tyre to test pressure.

Check

- Check the valve for leaks.

 Technical data			
Wheel valve test pressure		4 bar	

Result:

- Valve is leaking.

Measure:

- Replace the valve insert.

Result:

- Valve is leaktight.

Measure:

- Correct the tyre pressure.

 Technical data			
Tyre pressure, front	tyre cold	2.5 bar	

- Check the tyre and make sure the line is at a uniform distance from the rim flange all the way round.



(-) Statically balancing front wheel

- Level balancing jig (No. 36 3 601) with knurled screws (1) and level gauge (2).
- Insert balancing shaft (No. 36 5 571) in front-wheel bearing and secure it with tensioner (No. 36 5 572), making sure that front-wheel bearing is **lightly** preloaded.
- Remove old adhesive weights (3).
- Place the front wheel on the balancing jig and allow it to come to rest.
- Clean the attachment points for the adhesive weights.
- Affix **new** adhesive weights (3) opposite the heaviest point of the wheel.

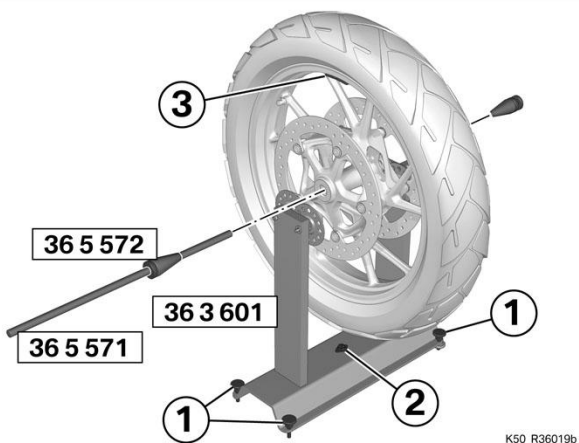

 Technical data			
Permissible front-wheel imbalance		max 5 g	
Balance weight for front wheel		max 80 g	
Weights have to be affixed with one half on the left and one half on the right, in other			

words centred on the rim			
-----------------------------	--	--	--

- Repeat the balancing procedure as a check.